T-Trac Installation Manual

Kundel's Underhung T-Trac Series Up to 10 Ton with Motorization

Model and Serial Number

SAMPLE MANUAL



Installation, Operation, and Maintenance Schedule for T-Trac Crane System up to 10 Ton

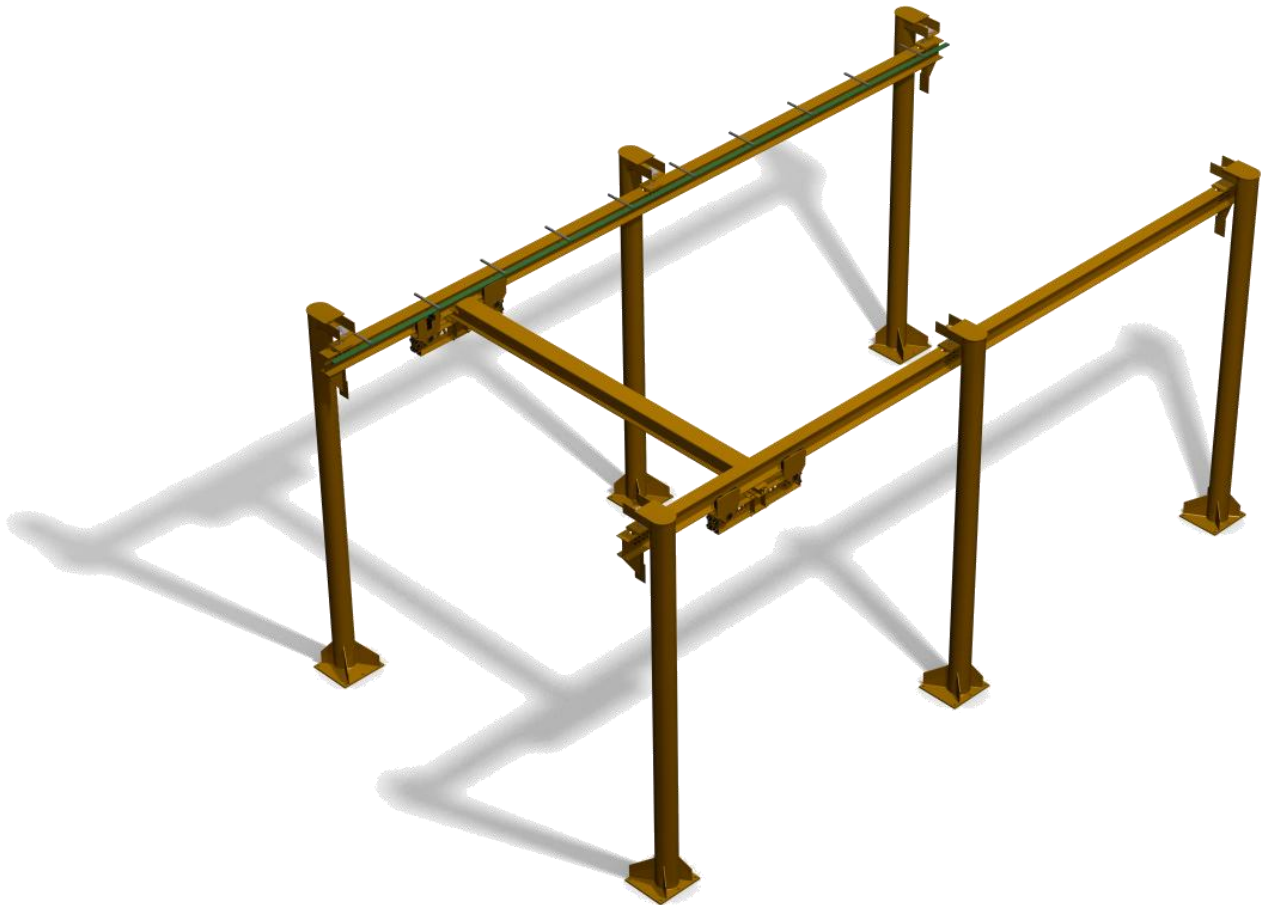

Thank you for choosing Kundel Industries' T-Trac crane system, in meeting your material handling needs. Your system has been custom built to meet your needs and requirements. Spherical hanging points allow the system to hang plumb on an un-level surface along with dissipating any forces incurred during bridge travel. The smooth ramp up and ramp down combined with infinite speed control allows loads to be moved safely and securely.

By reading and applying the information from this manual, you will obtain dependable performance from our products. Therefore, it is important that you follow this manual to properly install and operate your T-Trac Series crane system. The owner and operator are responsible in determining the suitable product for a particular use. It is recommended that all applicable industry standards, and federal, state and local laws and regulations be checked concerning the installation, operations and maintenance of the T-Trac crane system. Please read all operating instructions and warnings before operating this crane.

Table of Contents

Section	Page No.
1.0	Important information and warnings
1.1	Terms and conditions 6-8
1.2	Warning Tags and Labels 8
1.3	o.s.h.a. standards 9
2.0	Technical Information
2.1	Floor Supported Systems 9
2.2	Building Structural Supported System 9
3.0	Assembly, Installation and Load Testing
3.1	Post 10
3.2	Beam Hangers 10
3.3	Runway 11-12
3.4	Motorized Trolley/Hoist 12-13
3.5	Bridge 13-14
3.6	Power 14-19
3.7	Testing 19-20
4.0	Operation
4.1	Crane Operators 20
4.2	General Safety Rules 20
4.3	Operation Rules 20-21
5.0	Inspection
5.1	General 21
5.2	Inspection classification 21-22
5.3	Frequent inspection 22
5.4	Periodic inspection 22-23

5.5	Occasional use of system	23
5.6	Inspection records	23
5.7	Inspection methods and Criteria	23
6.0	Troubleshooting	
6.1	Guide	23
7.0	Documents	
7.1	Collector-Wire Schematic	24
7.2	Inspection Criteria	25-26
8.0	Warranty	
8.1	T-Trac Warranty	27-28
9.0	Crane Inspection Log Sheet	
9.1	Annual Inspection Log Sheet	29
9.2	Periodic Inspection Log Sheet	30
10.0	Parts List	
10.1	Post/Hangers	31
10.2	Runway/Runway Assembly	32
10.3	Bridge	33
10.4	Endtrucks	34
10.5	Motorization	35
10.6	Wire	36
11.0	Other Kundel Products	
11.1	SnapTrac	37
11.2	K-Trac	38
11.3	T-Trac	39

1.0 Important information and warnings

1.1 Terms and conditions

KUNDEL INDUSTRIES, INC ADDITIONAL TERMS AND CONDITIONS

ACCEPTANCE OF ORDERS: Prices quoted in proposals submitted by Kundel Industries, Inc. (the "Company") expire thirty (30) days after submittal. Upon written or verbal acceptance by the Purchaser, the Company will prepare an "Order Acknowledgement" form signed by an officer of the Company, and mail or fax the same to the Purchaser. The Company reserves the right to accept Orders on the basis of prices in effect at the time the Order is received. The Order Acknowledgement may not be varied, modified, changed, or supplemented in any way, unless the change is approved by the Company in writing. All contracts shall be construed in accordance with the laws of the State of Ohio.

PAYMENTS: Payments on account are due and payable in full thirty (30) days after the shipment date. Past due accounts shall bear interest at the rate of 1.5% per month until paid in full. If Purchaser fails to perform as required herein, then the Company may terminate this Agreement and be relieved of all obligations hereunder. The Company reserves the right to place customers with past due accounts on a C.O.D. basis for new orders. Purchaser agrees to reimburse the Company all of its attorneys' fees and expenses incurred in collecting outstanding account balances. All orders for non-credit approved customers must be prepaid.

CANCELLATIONS: Cancellation of Orders may be made only with the Company's consent in writing. In the event of cancellation, Purchaser shall be liable for all material, labor, engineering, manufacturing and administrative overhead incurred previously or thereafter by the Company. Minimum cancellation charge is \$350.00, which charge shall be paid in full within ten (10) days after receipt by the Company of notice of cancellation.

QUOTING POLICIES: All prices quoted are subject to change without notice after thirty (30) days.

EQUIPMENT: Non-standard equipment may require field adjustments. The Company is not responsible for any costs associated with any field adjustments. Standard equipment is made from pre-engineered components that are assembled and built in a consistent manner for different crane kits. Only the Company shall determine if a crane system is non-standard.

EQUIPMENT CHANGES: The Purchaser shall be responsible for 10% of the structural subtotal that appears on the Quotation plus additional material costs and engineering costs if changes are not submitted by Purchaser and accepted by Company within three (3) days of Company's receipt of the order.

DELIVERY: Unless otherwise specified, all shipments made by the Company are F.O.B. the Company's factory, and the Company does not make any guarantee as to delivery at destination; all shipping dates are approximate only. Delivery dates are estimated from the date of Purchaser's order, with complete drawings, specifications, designs and other information required by the Company. Any shipment information given verbally to Purchaser during process of said order is only approximate and shall not be used to govern actions by Company in any manner whatsoever. The Company shall not be liable for delay in or failure to make delivery due to causes beyond its reasonable control, such as strikes, fires, epidemics, acts of God, war, riot, unavoidable delays such as back orders from suppliers and the like or for any reason beyond Company's control. The Company is not responsible for costs incurred by the Purchaser for incomplete or inaccurate shipments from the Company. Any and all whole and/or partial shipments are the sole responsibility of the Purchaser.

DEMURRAGE: If the Purchaser requests a delay in delivery and the Company agrees to such a delay, Purchaser is subject to any demurrage and storage charges involved. Purchaser agrees that payment of these charges does not relieve Purchaser from fulfillment of any other obligations by Purchaser specified by the contract. Purchaser is subject to any demurrage and storage charges involved, which shall be paid within ten (10) days of the invoice date.

DAMAGED GOODS POLICY: The following is the adopted practice for damaged goods.

- a) In order to receive any compensation for receipt of damaged goods whether due to shipping or a factory defect, Purchaser must sign the Bill of Lading as usual, but also must note on it that the equipment was received damaged. If, in the case that the equipment is damaged in shipping, Purchaser must pay Purchaser's shipping bill prior to compensation and for the insurance estimator to investigate any claim.
- b) Purchaser should contact the freight carrier immediately and have an estimator come out to inspect the load. This is Purchaser's responsibility since Company's product is shipped F.O.B. Company's factory.
- c) Next, Purchaser can place Purchaser's new order with the Company for the replacement components required. Purchaser will then receive an invoice on the new equipment purchased. Purchaser must then pay the new invoice amount in full.
- d) The Company is not responsible for any costs incurred by the Purchaser resulting from damage to goods due to shipping and transportation.
- e) If goods are damaged during shipping, the Bill of Laden must be signed and labeled "Damaged Goods" as stated above in this Paragraph, subparagraph (a). Any damages must be reported to the Company in writing within ten (10) days of the date of delivery. The Company shall then have a reasonable opportunity to remedy or repair said defects. Purchaser shall return all parts and components claimed to be defective to the Company. If such parts and components are not returned to the Company within 30 days after a claim is made, then Purchaser will be charged for the costs of the replacement parts and components. Purchaser is responsible for any expedited shipping costs, if expedited shipping is requested by Purchaser.
- f) No service, repairs, parts or back charges from Purchaser to the Company will be accepted unless the following protocol is strictly followed: Details of the occurrence must be documented along with clear photos, signed, dated and faxed over to the Company for review. The Company, at that time, will inform Purchaser what work is authorized to be performed and the time allocated to rectify the situation if deemed necessary by the Company. The Company reserves the right to deny any and all charges from the Purchaser and/or firm(s) representing the Purchaser if such charges are determined by the Company to be unreasonable or not necessary. A requisition or work order will be given by the Company before any work is performed by the Purchaser or any other firm(s) representing the Purchaser on the equipment purchased.

ERECTION: Unless otherwise stated by the Company in writing, the equipment shall be installed and erected at the sole expense of the Purchaser. If the Company agrees to provide supervisory service, it is agreed that such services are advisory in nature and the Company will be held harmless from claims of any person or entity of any nature whatsoever. The supervisory person(s) will be paid an hourly rate per person per eight (8) hour day with time and one-half for Saturday work and time and one-half for all hours in excess of an eight (8) hour day and triple time for Sunday or holiday work. Purchaser will also be billed for all expenses incurred from the time the person leaves the Company facility until return, such as transportation, meals and lodging. All such charges will be paid by the Purchaser to the Company within thirty (30) days after the invoice date.

CREDIT: All orders are subject to credit approval. The Company may refuse shipment or cancel unfilled orders if the Purchaser is delinquent in any payment or the status of the account warrants it or if the Company deems itself to be insecure.

TAXES: The amount of any Federal, State or Municipal taxes applicable to the equipment covered by this order, shall be the responsibility of the Purchaser.

RESPONSIBILITY: No responsibility will be assumed by the Company for any changes or alterations made by the Purchaser nor for work done or expenses incurred by the Purchaser in connection with repairs or replacements, except as authorized in writing by an officer of the Company, namely the President, Vice-President and/or Head of Operations of the division responsible for such order.

WARRANTY: The Company warrants that new equipment will be free from defects in materials and workmanship for a period of one year from date of shipment and used or "refurbished" equipment will be free from defects in material and workmanship for a period of six months from the date of shipment, unless otherwise stated in writing. This warranty is made in lieu of all other warranties, express or implied, oral or written. The use of any sample or model during negotiations prior to the formation of any contract serves merely to indicate the type of goods tendered to the Purchaser. THE COMPANY HEREBY DISCLAIMS ANY IMPLIED WARRANTIES OF MERCHANTABILITY AND FITNESS FOR PURPOSE. This warranty shall extend only to the original Purchaser and not to any party which may acquire the equipment from the Purchaser, by any means whatsoever. This warranty is further limited to the following defects:

- a) Parts that were incorrectly machined by the Company.
- b) Parts that were manufactured with discrepant material which caused premature wear or breakage.
- c) Parts that were incorrectly assembled by the Company.
- d) Equipment that was not furnished in accordance with the written sales order received from the Purchaser.

THIS WARRANTY BECOMES NULL AND VOID UNDER THE FOLLOWING CONDITIONS:

- a) Equipment overload or abuse.
- b) Equipment alteration and/or use of non-Company replacement parts by Purchaser or its agent.
- c) Use of any equipment in any manner or for any purpose not considered normal intended use.

Further, Company accepts no liability whatsoever for special or consequential damages caused to Purchaser or others.

WARNING: The Company's material handling equipment is intended for industrial and other material handling applications. It is expected that the equipment is properly used and maintained by the Purchaser in accordance with all design specifications and/or limitations, and all applicable federal, state and local statutes, laws, orders, rules and regulations. The equipment is not to be used as a source of transportation or entertainment.

SECURITY INTEREST: The Company retains a security interest in all equipment and goods sold pursuant to this Agreement until payment in full is received by the Company. Purchaser hereby authorizes the Company to file financing statements to evidence the security interest reserved by the Company hereunder. If the Purchaser fails to pay its account in full when due, then the Company may obtain immediate possession of the equipment and goods by all legal means. The Company also has the right to terminate outstanding contracts in the event of a default by the Purchaser.

GOVERNING LAW: This Agreement shall be construed and interpreted in accordance with the laws of the State of Ohio and the parties hereby consent to the exclusive jurisdiction and venue for the determination of any dispute arising hereunder or to Purchaser's account to be in the Mahoning County Court of Common Pleas in Youngstown, Ohio, or the Federal District Court for the Northern District of Ohio, Eastern Division.

1.2 Warning Tags and Labels

1.3 o.s.h.a. standards

A complete copy of OSHA's standard and regulations are available for you to read at the U.S. Department of Labor (www.osha.gov). Recently, OSHA has joined forces with CMAA, HMI and MMA Alliance focuses on providing crane system owners and operators, like you with information, guidance, and access to training resources that will help you protect your employees' health and safety. Their goal is to focus on reducing and preventing exposure to workplace hazards associated with amputations and ergonomics. These goals include Outreach and communication, and Promoting the national dialogue on workplace safety and health:

A full library of publications and resources are available on the Material Handling Industry of America's web site www.mhia.org. Here you will find helpful guide to building and promoting safety for your shop. Some of these items consist of; Fundamental of Overhead Crane Safety Training Program, Overhead Crane Inspection and Maintenance Checklist, ect.

2.0 Technical Information

2.1 Floor Support Systems

When supporting your system from a floor foundation, be sure that your floor consists 7" of reinforced concrete at 4000 PSI. If you floor does not consist of this, please consult with a soils engineer to have them evaluate you floor for the proper footing that would need to be install first.

2.2 Building Structural Supported Systems

When supporting your system from a structural support (Vertical Beams, Overhead Beams, ect.) you want to make sure that you use all Grade 8 fasteners to assure maximum support. When welding any to a structural support be sure to use a ½" or greater fillet weld

3.0 Assembly, Installation and Load Testing

Below is a list of tools that you may find required when installing a standard T-Trac System.

Crane Plane, Layout, and Signed Proposal Drawings (plan view and Top View)

Wrenches: 9/16", ¾", 1-1/8"

Impact Wrench w/ 1-1/8"

Magnetic Torpedo Level

Transit or Tri-pod level

3 lbs. Hammer

Hammer Drill with ¾" concrete bit

Tape Measure

5/8" Allen Wrench

Philips and Flat head screw drivers

#4 & #5 Channel Locks

2 – Plumb bobs

Flashlight

Lifting Sling

2 – ½ Ton chain falls

2 – 6" C-clamps

3.1 Post

With the supplied signed off floor plan drawing, layout the base plate locations on the concrete.

Note: A base plate template can be created out of a piece of cardboard, or scrap piece of steel. String across face of post if possible to assure flush alignment of post, if not a laser may be necessary.

Drill holes in the concrete for anchors, making sure to use the proper drill bit for the anchor.

Example: A 7/8" X 8" anchors are required for system up to 4,000 lbs. Capacity. Refer to the chart below for the proper anchor bolt size for your floor-supported system.

Part No.	Thickness	Dimension	Anchor Bolt Size
NAP10	1"	18" X 23-1/2"	7/8" X 8"
NAP12	1"	27" X 29"	1-1/4" X 9"
NAP14	1"	30" X 30"	1" X 9"
NAP14-SCH80	1"	30" X 30"	1" X 9"
NAP16	1"	29" X 31"	1-1/4" X 9"
NAP16-SCH80	1"	29" X 31"	1-1/4" X 9"
NAP18	1"	36" X 36"	1-1/4" X 9"
NAP18-SCH80	1"	36" X 36"	1-1/4" X 9"

Fig. 3.1.1 Wedge Anchor Bolt Chart

Position the post onto the concrete over the correct hole locations. At this point make sure the anchor bolts are properly secured according to specs from the anchor provider.

The post is now ready for the runway sections to be hung from them.

3.2 Beam Hanger (If Applicable)

Remove top bolts on beam hanger, and slide or wrap hanger onto beam. Make sure the spherical washer is placed inside the beam hanger prior to installation. Attach washers and nuts provided for securing the beam hanger. The hanger should be tight on the beam as not to slide or damage any components.



fig. 3.3.2 make sure all hardware has been hand tighten on the beam hanger before hanging any runways from the ceiling.

3.3 Runway

On any systems requiring more than four hanging points refer to the supplied signed off plan view drawing to assembly the rail sections together before hanging each runway. You will find that each rail section on the drawing is labeled (example R1, R2, R3, ect.), and matches the physical section. Based on the drawing, match the adjacent joined rail section together and assemble the two sections using the runway hangers (see fig. 3.3.1).

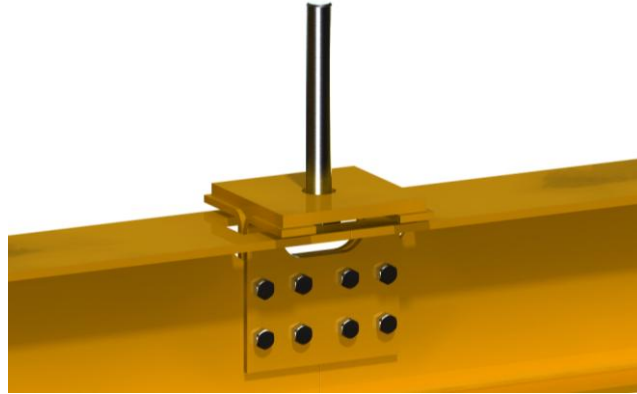

fig. 3.3.1 make sure all bolts have been hand tighten before hanging the complete runway from their supports

Once the runways are completely assembled you may find that installing the electric buss bar is much easier on the ground rather than once the runways are in place and attached to their hanging points. Please refer to section 3.6 for detailed instructions of this process. With proper rigging, lift the completed runway into place and position the hanging rod thru the post top block assembly. Using the spherical bearing nut and jam nut, hand tighten them in place (see fig. 3.3.2).



fig. 3.3.2 make sure all hardware has been hand tighten before removing the rigging from each runway.

Once both runways are hanging in place, the runways can now be leveled. Using a transit, or laser is recommended for accuracy (see fig. 3.3.3). When both runways are lever and true, you will need to attach the runway stops on both of the runways at one end. With runway stops not attached at the other end, you are now ready to install your bridge(s) and possible rolling buffers (if required) (see fig. 3.3.4).

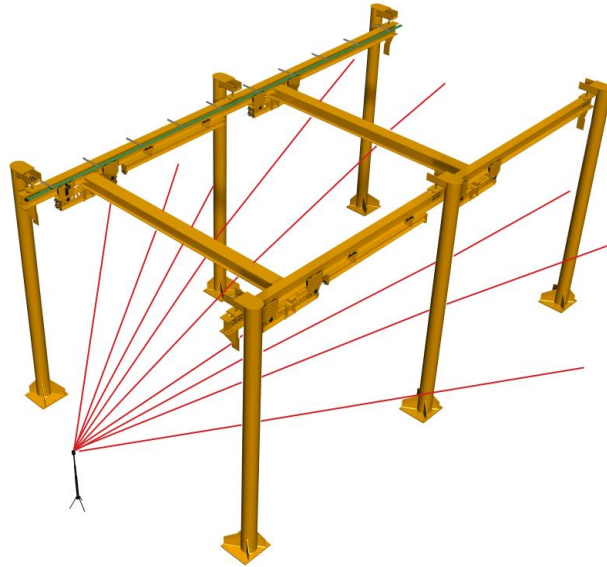

fig. 3.3.3 Using a transit, or laser is recommended for accuracy

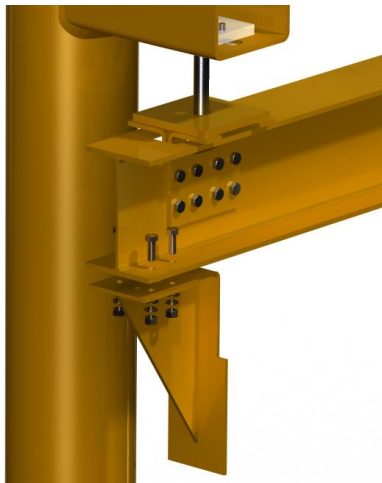

fig. 3.3.4 make sure all hardware has been hand tightened, failure to do so could result in death or serious injury, and/or property damage.

Once the bridge(s) and possible rolling buffers (if required) have been installed you will need to attach the remaining bridge stops at the other end. Again making sure all hardware has been hand tightened.

3.4 Motorized Trolley/Hoist

Prior to installing the bridge it is important to attach the motorized trolley/hoist too. You may find it easier attaching your trolley/hoist closer to the ground rather than once it is hanging in the air. If you are unable to attach you (motorized) trolley to the bridge without removing one of the endtruck, carefully remove the endtruck (see fig. 3.4.1), and slide on the trolley from one end. Be sure to re-attach the endtruck, firmly tightening all fasteners before lifting the bridge in the air and mounting it onto the runway sections.

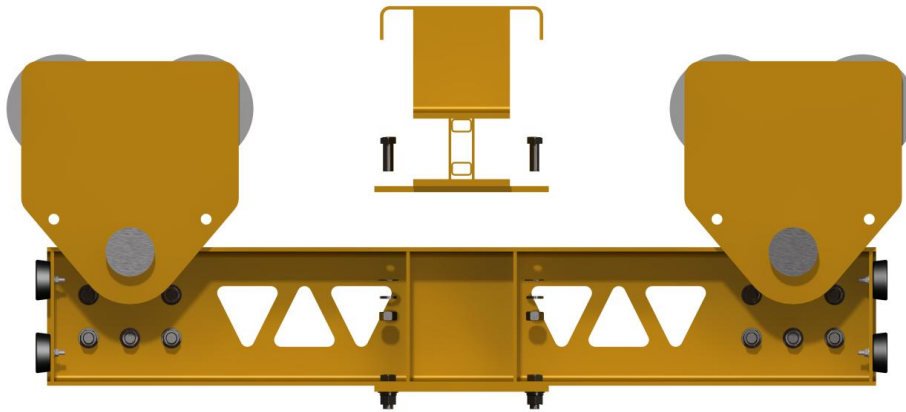

fig. 3.4.1 be sure to disconnect all electrical wires, and loosen the hardware that attached the endtruck to the bridge before removing the endtruck. Make sure you firmly tightening all fasteners for the endtruck assembly before lifting the bridge in the air and mounting it onto the runway sections.

3.5 Bridge

Once both runways have been installed properly you are ready to position the bridge(s) on both runway sections. Using proper rigging the bridge should be raised in position, and steadied. Carefully move the bridge down the runway section making sure that on both endtruck wheels are properly being lowered and that the bridge is suspended from the runway track correctly. Be sure to move the bridge far enough back, making certain that it will not roll back towards the open/exposed end for the runways (see fig. 3.5.1), before removing the rigging from the bridge.



fig. 3.5.1 make sure all endtruck wheels are making proper contact with the runway before removing any rigging from the bridge.

For multiple bridges where rolling buffers are required, the first bridge must be in position on the runway and move clear to the end of the system. Then one rolling buffer at a time raise and position them onto the runway, and moving them all the way to the end of the system, so they touch the bridge's endtruck at the end of the system. Once both rolling buffers have been put into position the next bridge can be installed and moved to the end of the system so it is all the way against the rolling buffers (see fig. 3.5.2).



fig. 3.5.2 makes sure both bridges and rolling buffers are push clear to the end of the system against the bridge stops. This will prevent the threat of the bridges rolling toward the open end before the remaining bridge stops can be installed.

If your system is designed for three plus bridges and rolling buffers, repeat this process making sure each time the buffer and/or bridge is moved as far as possible to the end of the system. Doing so will enable you to install the remaining runway sections without threat of the bridges rolling toward the open end, if not avoided, could result in death or serious injury, and property damage.

Once the all required rolling buffers and/or required bridge(s) has been installed it is important to attach the remaining bridge stops to the open end. All hardware should be hand tightened prior to proceeding. Failure to do so could result in death or serious injury, and/or property damage

The mechanical or structural installations portion is complete. Be sure to locktite all structural fasteners prior to installing the power portions of the system. Be sure to refer and comply with the required torque standards for the structural fasteners for both ASME/ANSI standards and Crane Manufacturer's Association of America standards (CMAA).

3.6 Power

To begin the process of assembling the power to the system, you must first assemble all bussing on the power side of the runway. You may find this total process of installing the buss bar much easier on the ground rather than once the runways are in place. You begin doing this by attaching all of the clips onto the buss bar hanging bracket located on top of the power side of the runway. Be sure to attach it them to the inside of the crane system (see fig. 3.6.1), because the collector bracket is located on endtruck. At this time you will only want to finger tighten them, because this will give the clips a little flexibility when inserting the buss bar.



fig. 3.6.1 be sure to only finger tighten them, for ease of inserting the buss bar and alignment.

Once all bussing clips are in place begin sliding or snapping the first stick of buss bar into the one end of the system working it clear to the end of the runway. Once you have the first buss bar stick into place you will want to slide the next stick in as well making sure that the yellow conductor is on the same side as the previous bar. Once the first two bars are next to each other you will begin process of joining the two sections together using the joint kits. To do so insert bussing fingers into one of the conductor bar with the pin side facing up. The pin should bottom out on the plastic housing (see fig. 3.6.2). Once the buss fingers are in place, the joint cover can now be slid into place (see fig. 3.6.3).

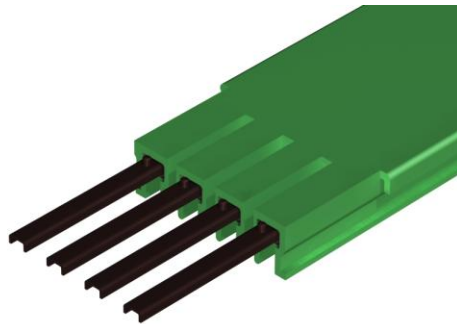

fig. 3.6.2 Pins should bottom out on the plastic housing.

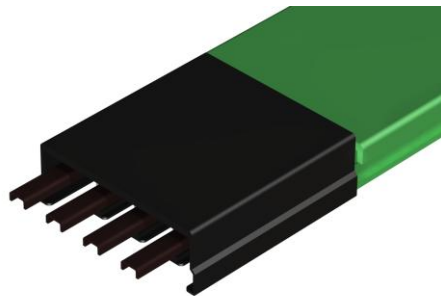

fig. 3.6.3 make sure the cover is firm in place

Once the buss bar joint cover is in place, the conductor bars can be brought together carefully, making sure the yellow conductor sides are aligned. Make sure that the transitional buss bar fingers slide into

the adjoining bus bar track. Failure to do so can result in buss bar damage and power loss (see fig. 3.6.4).

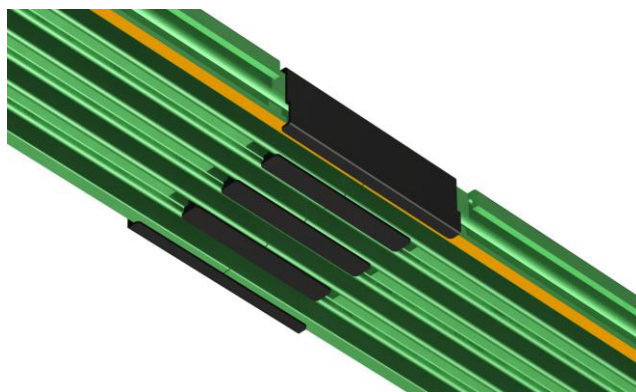

fig. 3.6.5 Failure to make sure all the yellow conductors are aligned, and bar finger are slid in tight to adjoining buss bar track may result in buss bar damage and/or power loss.

The next step once the buss bare has been joined and the bridge(s) have been installed is to wire the endtruck collector to the main power cord attached to the bridge control box. Please refer to the attached wire schematic in Document section 7.0 in the back of your system installation manual (Doc. 7-3.6.1). Once the collector has been properly wired you are ready to attach the endtruck collector to the adjustable collector bracket located on the power side for the endtruck. Make sure the yellow shoe on the collector is in line to be inserted in the yellow track on the buss bar (see fig. 3.6.5).



fig. 3.6.5 Make sure the yellow shoe on the collector is in line with the yellow on the buss bar track. Failure to do so may result in buss bar damage and/or power loss.

Once the collector is tightened adjust the collector bracket on the power side of the bridge raising the collector so it can make firm contact with the conductor bar attached to the runway. Take extra care to insert the yellow conductor arm into the yellow coded side of the electric buss bar (see fig. 3.6.6). All conductor shoes should be aligned in their proper track in the buss bar. Failure to do so can result in electrical damage and power failure.



fig. 3.6.6 Take extra care inserting the yellow conductor arm into the yellow coded side of the electric buss bar

Once the endtruck collector has been inserted make sure the buss bar end cap is in place and firmly attached. The buss bar cap should bottom out when fully inserted, and be secured with the screws provided (see fig. 3.6.7).

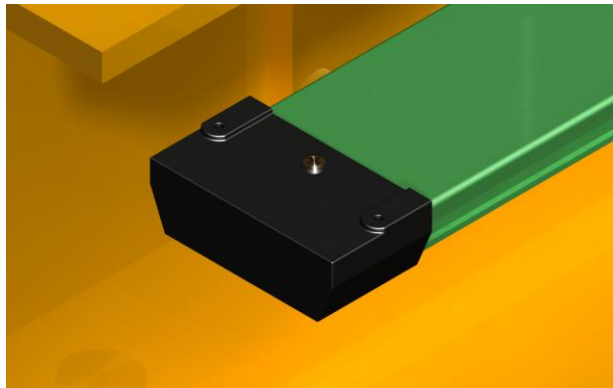

fig. 3.6.6 The buss bar end cover should bottom out. Be sure to secure the cap with the screw to keep the collector from sliding out the end of the track and/or getting damage.

The Kundel T-Trac motorization system comes standard with compiled components from R&M, on both the electrical and motor components. In the attached appendix you will find a complete manual for your endtruck motors, bridge control box, festoon pendant and wire schematic.

Please refer to the attached manuals for any technical questions regarding the motorization of your system. This portion of the Kundel T-Trac Manual only covers the general installation and operations of your system. Each Kundel T-Trac system comes standard with a VFD (see fig. 3.6.7). You may find that this control is set all the way down coming from the factory at their default settings. Consult the R&M manual for directions on how to adjust this control (Please refer to tab #2 for directions on R&M's products). For electrical engineering questions please feel free to call Rick E. Lee, of R&M at (937)525-5119.



fig. 3.6.6 R&M's standard VFD Control located inside the bridge control panel.

The next step in installing the electric for your T-Trac system to make sure that all the proper wires are connected coming/going from the bridge control box. First connect the endtruck collector plug into the other half of the incoming power on the bridge control box. Next make sure that the power going from the bridge control box is properly attached to the endtrucks' motors.

On the other side of the bridge runs two yellow conductor wires parallel of each other. On one outside of the bridge the conductor wire is attached to Kundel's standard used 8-button pendant ((see fig. 3.6.8) unless otherwise requested). On the inside, next to the bridge runs the power conductor wire ((see fig. 3.6.9) with R&M's standard hoist plug) to supply power to your trolley/hoist. At this point be sure to refer to the manual that came with your hoist as well as the wire schematics in the attached appendix (Please refer to tab #1 for all wire schematics for R&M products). Failure to properly attach your hoist to these wires may result in damage to hoist and/or system motorization.



fig. 3.6.8 Kundel's standard 8-Button pendant.



fig. 3.6.9 R&M's standard hoist plug.

Once the trolley(s)/hoist(s) have been attached properly, you are finally ready to attach the main power coming into the system. Referring back to supplied signed off plan view drawing; you will find the desired locations of the incoming electric agreed on prior to manufacturing of your system.

When installing the electric Buss Bar, this should have been the last piece joined together. You will find a wiretap (15' – 14 AWG4 conductor cable) at one end of this piece of Buss Bar has a 15' – 14 AWG4 conductor cable attached to one end. At this point your qualified electrician may now bring power to your system by attaching the supplied wiretap to your main power source (junction, breaker, panel, Ect.).

3.7 Testing

When undergoing a newly installed crane system a Load test should be preformed. A Certified Kundel Crane Installer/Inspector can assist or perform this test for you.

Load Testing

- Newly installed cranes and hoists shall be load tested at 125% of the rated capacity by designated personnel.
- Slings shall have appropriate test data when purchased. It is the responsibility of the purchaser to ensure that the appropriate test data are obtained and maintained.
- Re-rated cranes and hoists shall be load tested to 125% of the new capacity if the new rating is greater than the previous rated capacity.
- Fixed cranes or hoists that have had major modifications or repair shall be load tested to 125% of the rated capacity.
- Cranes and hoists that have been overloaded shall be inspected prior to being returned to service.
- All cranes and hoists with a capacity greater than 2722 kg (3 tons) should be load tested every four years to 125% of the rated capacity. Cranes and hoists with a lesser capacity should be load tested every eight years to 125% of the rated capacity.

4.0 Operation

All workers who use any Kundel Industries' crane should have an operator's license (if your company issues license for authorization), or be a competent person who has been specifically trained in crane and hoist operations and equipment safety.

4.1 Crane Operators

To be qualified as a Crane Operator, the employee must receive hands-on training from a licensed and/or qualified crane operator designated by the employee's supervisor. Upon successful completion of training, the licensed crane the candidate will be issued a license upon approval by the Safety Manager (if applicable). Crane and Hoist Operators must renew their license every three years and undergo annual safety operations review by Safety Manager (if applicable).

4.2 General Safety Rules

Operators shall comply with the following rules while operating the cranes and hoists:

- Be sure to remain focus at all times; do not allow anything to divert your attention while operating the crane.
- When using signals be sure to only respond to the person who is directing the lift, or any appointed signal person. Obey a stop signal at all times, no matter who gives it.
- Never move a load over people. People shall not be placed in jeopardy by being under a suspended load. Also, do not work under a suspended load unless the load is being supported by something else that will safely support the entire weight. Have a crane or hoist operator remain at the controls or lock open and/or tag the main electrical disconnect switch.
- Ensure that the rated load capacity of a crane's bridge, an individual hoist, or any sling or lifting tool/device is not exceeded. Be sure to always know the weight of the object you are lifting to avoid over loading of any device or the crane its self.
- Check that all controls are in the OFF position before closing the main-line disconnect switch.
- Avoid side loading or pulling. These can cause the hoist rope to slip out of the drum groove, damaging the rope or destabilizing the crane or hoist.
- To prevent shock loading, avoid sudden stops or starts. A VFD is standard for all Kundel T-Trac systems to avoid situations like this. Example shock loading can occur when a suspended load is accelerated or decelerated, and can overload the crane or hoist. When completing an upward or downward motion, ease the load slowly to a stop.

4.3 Operation Rules

Pre-operational Test

At the start of each work shift, operators shall do the following steps before making a lift with any crane or hoist:

- If your hoist has an upper-limit switch be sure to test it at the beginning of each shift. Slowly raise the unloaded hook block until the limit switch trips.
- Visually inspect the hook, load lines, trolley, and bridge as much as possible from the operator's position on the floor. Check for any defects or frays, if any are spotted report it to your supervisor before operation your crane.
- If provided, test the lower-limit switch as well.
- Test all direction and speed controls for both your bridge and trolley.
- Test all bridge and trolley limit switches, if applicable.

- Test the pendant emergency stop.
- Test the hoist brake to verify there is no drift without a load.
- If provided, test the bridge movement alarm.
- Lock out and tag for repair any crane or hoist that fails any of the above tests and report it to your Supervisor.

Moving a Load

- Center the hook over the load to keep the cables from slipping out of the drum grooves and overlapping, and to prevent the load from swinging when it is lifted. Inspect the drum to verify that the cable is in the grooves.
- Be sure to use a tag line when loads are traveling long distances or must otherwise be controlled. Manila rope may be used for tag lines.
- Plan and check the travel path to avoid personnel and obstructions.
- Lift the load only high enough to clear the tallest obstruction in the travel path. Never carry a load over a person or walk path without roping it off first.
- Start and stop slowly.
- Land the load when the move is finished. Choose a safe landing.
- Never leave suspended loads unattended.

5.0 Inspection

All tests and inspections shall be conducted in accordance with the manufacturer's recommendations to uphold your cranes warmest.

5.1 General

A general should be done each day or the beginning of each shift (when an operator may change).

- If your hoist has an upper-limit switch be sure to test it at the beginning of each shift. Slowly raise the unloaded hook block until the limit switch trips.
- Visually inspect the hook, load lines, trolley, and bridge as much as possible from the operator's position on the floor. Check for any defects or frays, if any are spotted report it to your supervisor before operation your crane.
- If provided, test the lower-limit switch as well.
- Test all direction and speed controls for both your bridge and trolley.
- Test all bridge and trolley limit switches, if applicable.
- Test the pendant emergency stop.
- Test the hoist brake to verify there is no drift without a load.
- If provided, test the bridge movement alarm. Lock out and tag for repair any crane or hoist that fails any of the above tests and report it to your Supervisor.

5.2 Inspection classification

Kundel's T-Trac system falls under classification group "C". CLASS C (MODERATE SERVICE) - This service covers cranes that may be used in machine shops or paper mill machine rooms, etc., where service requirements are moderate. In this type of service the crane will handle loads which average 50

percent of the rated capacity with 5 to 10 lifts per hour, averaging 15 feet, not over 50 percent of the lift at rated capacity.

5.3 Frequent inspection

A frequent test and inspections should take place monthly on all Kundel Cranes to a sure ample use of your system and to avoid unwanted ware from improper use or installation of your crane system.

- All in-service cranes and hoists shall be inspected monthly and the results documented on the provide Kundel T-Trac Inspection form located in the Frequent Inspection Log Sheet (section 9.1), and kept in Maintenance Office.
- Defective cranes and hoists shall be locked and tagged "out of service" until all defects are corrected. The inspector shall initiate corrective action by notifying the facility manager or building coordinator. If more sheets are required please feel free to make a copy of one of the forms.

5.4 Periodic/Annual inspection

The Certified Kundel Crane Inspector will need scheduled to supervise (or perform) annual preventive maintenance (PM) and annual inspections of all Kundel cranes and your required hoists. The annual PM and inspection shall cover

- Hoisting and lowering mechanisms.
- Trolley travel or monorail travel.
- Bridge travel.
- Limit switches and locking and safety devices.
- Structural members.
- Bolts or rivets.
- Sheaves and drums.
- Parts such as pins, bearings, shafts, gears, rollers, locking devices, and clamping devices.
- Brake system parts, linings, pawls, and ratchets.
- Load, wind, and other indicators over their full range.
- Gasoline, diesel, electric, or other power plants.
- Chain-drive sprockets.
- Crane and hoist hooks.
- Electrical apparatus such as controller contractors, limit switches, and push button stations.
- Wire rope.
- Hoist chains.
- Finally, once the annual preventive maintenance (PM) and annual inspections has been completed the Certified Kundel Crane Inspector must complete the Kundel T-Trac periodic/annual Inspection Log Sheet located in section 9.2 of your Kundel T-Trac Manual. If more sheets are required please feel free to make a copy of one of the forms.

For periodic use of your system (where your system may sit idle for 30 days or more, the same inspection needs to take place. This inspection can be done by one of your maintenance person, however an annual inspection by a Certified Kundel Crane Inspector is required to uphold your T-Trac warranty with Kundel Industries, Inc.

5.5 Occasional use of system

For occasional use of your system (where your system may sit idle for 30 days or more, the same periodic/annual inspection needs to take place. This inspection can be done by one of your maintenance person; however an annual inspection by a Certified Kundel Crane Inspector is required upholding your T-Trac warranty with Kundel Industries, Inc.

5.6 Inspection records

It is important to keep a good record of your system, and to schedule annual inspections as well. Not only does it guarantee the manufacture warranty, but it assures you that will obtain a dependable performance and satisfaction from your Kundel system. Once again Kundel annual inspection, and suggested that you have it done by a Certified Kundel Crane Inspector. Feel free to call us at 330.259.9009.

6.0 Troubleshooting

For questions regarding any installations problems, operations of your crane please feel free to call Kundel direct to call 330.259.9009.

7.0 Documents

The following pages consist of document that you will find helpful when installing your Kundel T-Trac System.

7.1 Collector – wire schematic

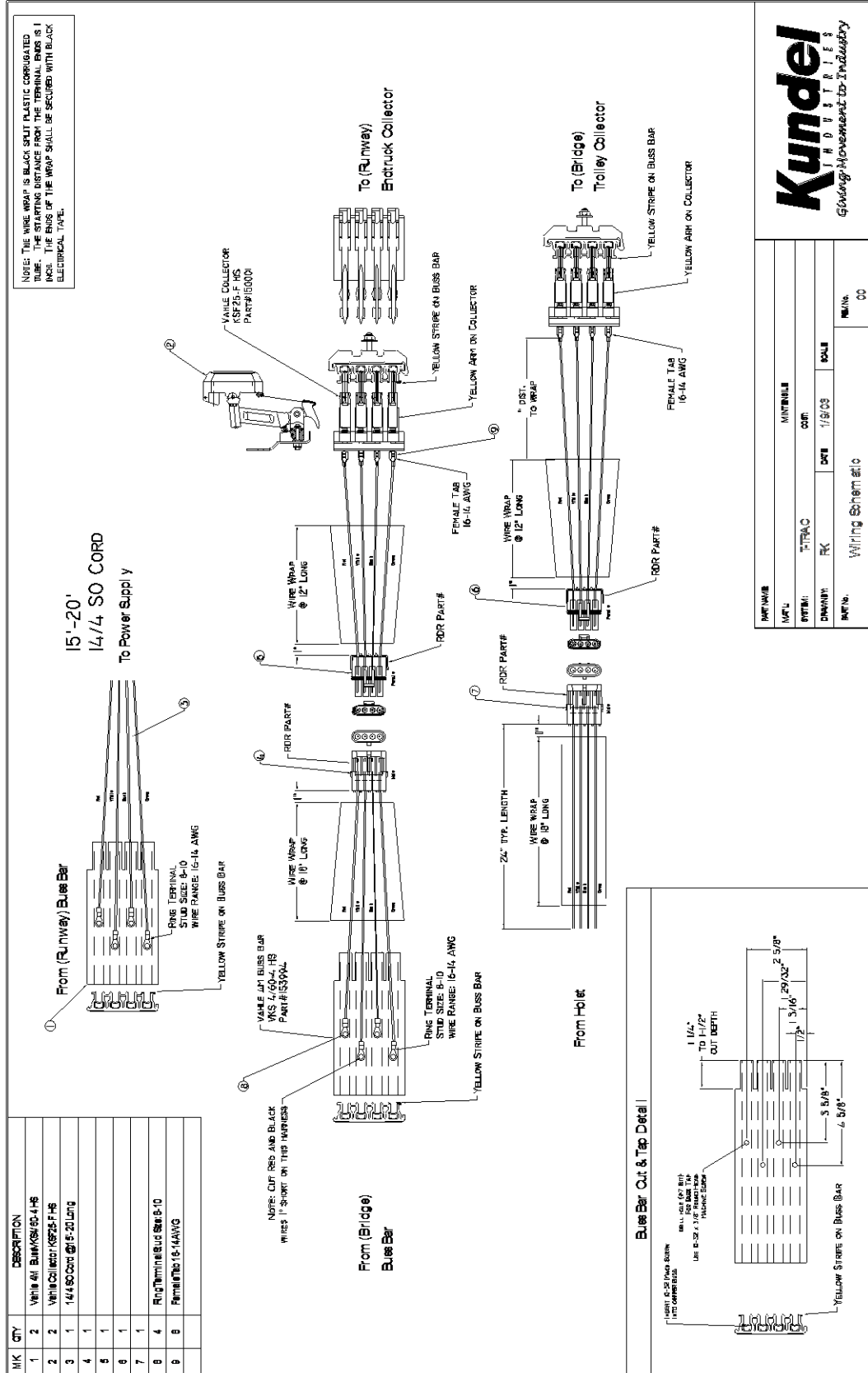

DATE:	1/18/03	SCALE:	1:1
BY:	TRAC	CHKD:	CC
APP'D:	Wiring Schematic		

7.2 Inspection Methods and Criteria

KUNDEL INDUSTRIES T-Trac Crane Inspection Check-off Sheet	
Location: _____ Address: _____ _____ _____	System # _____ Inspection Co. _____ DATE: _____

Description of Inspection:	Please check if applicable		
	Yes	No	N/A
1. All Post footings are properly secure			
1a. Leveled			
1b. Anchor bolts tightened			
2. All hangers to be according to print			
2a. All securing bolts to be tightened to spec.			
2b. Hanger Blocks to be set and tightened to spec.			
3. All hangers rods are properly adjusted			
3a. Hanger bolt greased at ball sockets			
3b. Coupling nut tightened			
3c. Rod adjusted to level rail			
3d. Nuts on rods jammed			
3e. Hanger blocks to be set and tightened to specs.			
4. Rail ends stops properly secured			
4a. Bolts tightened to CMAA standards			
5. Runways to be parallel, level and corresponding elevations			
5a. Centerlines correct according to print			
5b. Runways level for optimum performance			
5c. Elevations to meet customer requirements			
6. Bridge(s) to be level			
6a. Under Girder line should be according to print			
7. End Truck(s)			
7a. Endtrucks bolted showing no signs of wear			
7b. Endtrucks bolts to have fasteners properly installed			
7c. Endtrucks wheels to be free of debris			
7d. Endtrucks hanging points showing no sign of wear			

8. Trolley(s)	
8a. Trolley(s) showing signs of visible connection wear	
8b. Connection between Trolley properly installed	
8c. Trolley wheels to be free of debris	
8d. Trolley hanging points showing no signs of wear	
9. All runway and bridge track clean and free of debris	
9a. Clean Runway Track(s)	
9b. Clean Bridge track(s)	
10. All electric connections secure and functioning Proper	
10a. Voltage supply correct	
10b. Bussing functioning properly	
10c. Collectors properly installed and function proper	
10d. Lifting apparatus(s) hung correctly and power input correct	
11. Festooning supplies functioning properly	
11a. Rollers and cable installed and functions properly	
12. Hoist Function Properly	

Inspector Signature _____

Date _____

Title _____

<i>Crane Load Test Certification</i>	
Serial # _____	
hereby certifies system	_____
(Load testing firm)	(system dimensions)
has been load tested to 125% of it's rated capacity	_____ Lbs.
_____ Technician	_____ Date
<i>Note: This load test is performed in accordance with CMAA and ASTM standards</i>	

8.0 Warranty

8.1 T-Trac Warranty

The Company warrants that new equipment will be free from defects in materials and workmanship for a period of one year from date of shipment and used or "refurbished" equipment will be free from defects in material and workmanship for a period of six months from the date of shipment, unless otherwise stated in writing. This warranty is made in lieu of all other warranties, express or implied, oral or written. The use of any sample or model during negotiations prior to the formation of any contract serves merely to indicate the type of goods tendered to the Purchaser. THE COMPANY HEREBY DISCLAIMS ANY IMPLIED WARRANTIES OF MERCHANTABILITY AND FITNESS FOR PURPOSE. This warranty shall extend only to the original Purchaser and not to any party which may acquire the equipment from the Purchaser, by any means whatsoever. This warranty is further limited to the following defects:

- e) Parts that were incorrectly machined by the Company.
- f) Parts that were manufactured with discrepant material, which caused premature wear or breakage.
- g) Parts that were incorrectly assembled by the Company.
- h) Equipment that was not furnished in accordance with the written sales order received from the Purchaser.

THIS WARRANTY BECOMES NULL AND VOID UNDER THE FOLLOWING CONDITIONS:

- d) Equipment overload or abuse.
- e) Equipment alteration and/or use of non-Company replacement parts by Purchaser or its agent.
- f) Use of any equipment in any manner or for any purpose not considered normal intended use.

Further, Company accepts no liability whatsoever for special or consequential damages caused to Purchaser or others.

9.0 T-Trac Warranty

Kundel's Warranty Commitment

With *Kundel Industries* you get more than the industry's best custom crane. You get service and support after the sale that is unmatched. We strive to maintain a solid client relationship and have set a new standard in the industry for customer satisfaction. Kundel keeps delivering for the life of your custom crane.

Kundel Industries Crane Warranty

Kundel Industries, Inc. warrants to the original purchaser its Products to be free of defects in material and workmanship for a period of two years unlimited use, and five year (10,000 hours of use), from the date of purchase. *Kundel Industries, Inc.* will replace any parts found to be defective. Replacement parts are warranted for the remainder of the original warranty period. Warranty does not cover the installation of the replaced part. If any Products prove defective within its original warranty period, it should be returned, if needed, to any Authorized Distributor, transportation prepaid with proof of purchase or Warranty Certificate.

Kundel also offers a Limited Lifetime Warranty on defects in material and workmanship**.

This warranty does not apply to Products which *Kundel Industries, Inc.* determined to have been misused or abused, improperly maintained by the user, or where the malfunction or defect can be attributed to the use of non-genuine *Kundel Industries, Inc.* Product or Part. The warranty does not apply to normal wear and tear on Crane system.

Kundel Industries, Inc. makes no other warranty, and all implied warranties including any warranty of merchantability or fitness for a particular purpose are limited to the duration of the expressed warranty period as set forth above. Kundel Industries, Inc. maximum liability is limited to the purchase price of the Product and in no event shall Kundel Industries, Inc. be liable for any consequential, indirect, incidental, or special damages of any nature rising from the sale or use of the Product, whether based on contract, tort, or otherwise.

*****To qualify for the Limited Lifetime Warranty, the Crane System must have an annual inspection by a certified Kundel dealer. Normal wear and tear not included.***

9.0 Crane Inspection Log Sheet

The following pages contain log sheets for both annual and periodic inspection sheets. You may want to make an extra copy for a back up for when a sheet is filled up.

KUNDEL



3710 Hendrick Road, Austintown, Oh 44515

Toll Free 877.586.3353, Phone 330.259.9009, Fax 330.259.9001